



Triton Positive Pressure Units

Description

The Triton range of units has been developed to eliminate moisture from the home by a constant circulation of gently pressurized clean air.

Mounted either in the loft area of a house or a hallway cupboard of a flat, the gentle pressurization of the property expels any stale, humid air through natural ventilation points which are present in even the most insulated buildings.

The **Triton PPU Loft** is designed for installation in a loft area. The unit has a manually-operated switch which runs the unit either on slow speed, fast speed or turns the unit off.

The **Triton PPU Flat** – is designed for installation in properties without lofts. The unit works as the Triton PPU Loft and is normally installed in a hallway cupboard with ducting run to the unit from outside and then from the unit to a point near to the centre of the property.

Key Benefits

- Extract rate 55 litres/sec fast speed, 44 litres/ sec slow speed
- Options for loft or cupboard installation
- British made
- 2 year no quibble guarantee
- CE approved



Triton PPU Loft

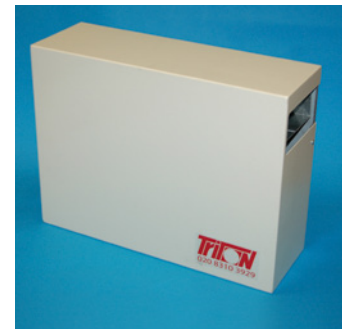

Triton PPU Flat

Technical Data

Loft mounted model for properties with lofts

| Product | Type |
|-----------------|--|
| Triton PPU Loft | Complete with 2-speed Manual switch (slow – off – fast). |

Cupboard mounted model for properties without lofts

| Product | Type |
|-----------------|--|
| Triton PPU Flat | Complete with 2-speed Manual switch (slow – off – fast). |

Filters are fitted to all units to remove dust and dirt particles and prevent them from entering the home.

The air is delivered to the property either through a centrally located inlet grille mounted on the landing or hallway ceiling for the loft-mounted units or wall grille for the cupboard-mounted unit.

| | |
|--------------|--|
| Construction | The Triton PPU Loft is made from leather coated steel for strength, durability and finish. The Triton PPU Flat is made from high strength plastic. |
| Electrical | 220-230V ~ A.C. 50Hz Single phase consuming 30 watts max for both units. These units require an earth. All wiring must comply with current IEE regulations. A double pole isolating switch, having a contact separation of at least 3mm in all poles, must be used with a 3 amp fuse fitted. |
| Motor | Single phase induction motor with pre-oiled ball-bearings fitted for a long maintenance free life and protected by a thermal fuse. |
| Guarantee | Two year no quibble guarantee. |
| Installation | The fans are designed to be loft or cupboard mounted. The inlet grille must be mounted at least 1m from any smoke detectors but full installation and operating instructions are provided with each unit. |
| Performance | Both units supply rate of 44 litres/sec on slow speed and 55 l/s on fast. |
| Fan Speed | 2400 r.p.m. |
| Sound Volume | 25.0 dB(A) Maximum operating temperature 40°C. |

Positive pressure units are not included in the 2006 edition of the Building Regulations as a means to satisfying Building Regs.

Triton PPU Loft

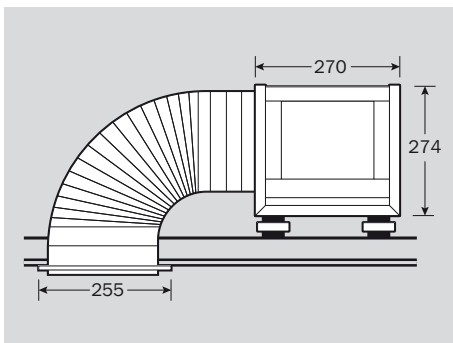

Triton PPU Flat

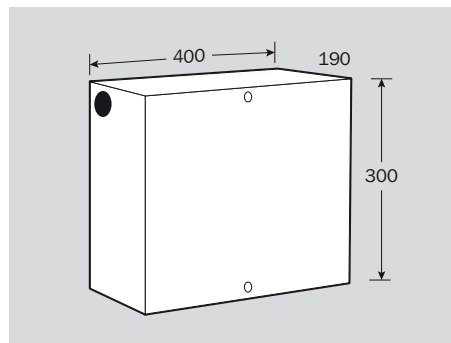

Triton Contact Details:

Triton Chemical Manufacturing Co. Ltd.
Unit 5, Lydean Industrial Estate, Abbey Wood, London SE2 9SG

Tel: 020 8310 3929

Fax: 020 8312 0349

Email: info@triton-chemicals.com

www.triton-chemicals.com