

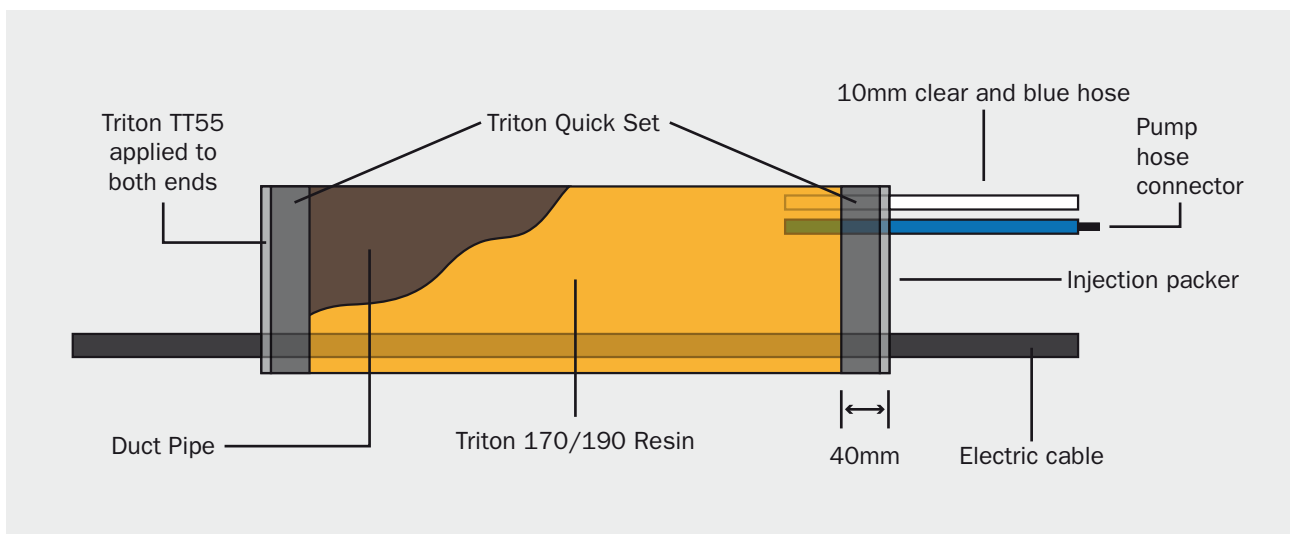

## Specification for Sealing Cable Ducts

### Methodology

1. Clean out the inside of the duct thoroughly of loose debris, dirt and contaminants.
2. Raise the cables from the bottom section of the duct so they are suspended throughout the duct length. This will ensure that the Triton 190 Resin will fully encapsulate the cables. Spray the inside of the pipe duct with clean water.
3. Using Triton Quick Set rapid setting mortar, plug both ends of the duct to a minimum depth of 40mm. To one duct end and whilst plugging the duct, install a clear and a blue 10mm hose at the top section (refer to drawing).



4. Once the Triton Quick Set has set, inject Triton 190 through the blue inlet hose until resin flows freely through the clear plastic tube.
5. Cap off the clear plastic tube and continue pumping until refusal.
6. Once the resin has fully cured, remove the clear and blue hoses and make good using Triton Quick Set. Clean down the surface of the resin residue (if required).
7. Once the Triton Quick Set has set, apply two coats of Triton TT55 to both ends of the duct. (Please refer to Triton TT55 data sheet for application instructions.)

### Important Notes

- a. The duct must be free of any material or solution that would interfere with the sealing process.
- b. Care should be taken when applying the Triton Quick Set to ensure the cables and clear tubing are surrounded as Triton 190 may escape around these locations.
- c. One of the tubes is to allow the air to escape from within the duct. The adjacent tube is used for the injection of Triton 190. Both tubes should be positioned so the ends are inside the duct void and not obstructed.
- d. If using a single piston pump, mix the Triton 190 components using a slow speed drill mixer to avoid excessive air entrapment. Mix the combined resin components for no less than five minutes to ensure adequate mixing.
- e. Ensure that the injection pump is thoroughly cleaned of resin material before the resin has had time to set within the pump. Triton 190 is a chemically reactive material and will react off faster in higher ambient temperatures.

## Typical Usage

Length	Diameter	Triton Quick Set	Triton 190
300	50	0.26kg	0.44 litres
300	100	1.00kg	1.73 litres
300	150	2.27kg	3.89 litres
400	50	0.26kg	0.63 litres
400	100	1.00kg	2.52 litres
400	150	2.27kg	5.66 litres
500	50	0.26kg	0.83 litres
500	100	1.00kg	3.30 litres
500	150	2.27kg	7.42 litres

The above quantities show typical usage and should be used as a guidance to material consumption only. Other factors such as wastage and allowances for internal cables should be taken into account when calculating consumption.

## Triton Contact Details:

---

Triton Chemical Manufacturing Co. Ltd.  
Unit 5, Lyndean Industrial Estate, Abbey Wood, London SE2 9SG

Tel: 020 8310 3929

Fax: 020 8312 0349

Email: [info@triton-chemicals.com](mailto:info@triton-chemicals.com)

[www.triton-chemicals.com](http://www.triton-chemicals.com)